

CONTACT

www.solpool.info
solpool@dgs.de

SOLPOOL Partners

- DGS: Project coordinator
Germany
www.dgs.de
- TTZ Bremerhaven
Germany
www.ttz-bremerhaven.de
- Centre for Renewable Energy Sources CRES
Greece
www.cres.gr
- Save-Rema Energy Agency
Hungary
www.save-rem.hu
- Czech RE Agency o.p.s
Czech Republic
www.czrea.org
- Save-Rema Energy Agency
Hungary
www.save-rem.hu
- Agence Locale de l'Énergie de l'agglomération Lyonnaise
Lyon, France
www.ale-lyon.o
- Provincia di Lecce
Lecce, Italy
www.provincia.le.it

Design

- Dagmar Melzer, Mediengestalterin
E-Mail dagmar.melzer@gmx.net
Tel. 0179-481 37 23

SOLPOOL

Solar outdoor pool heating

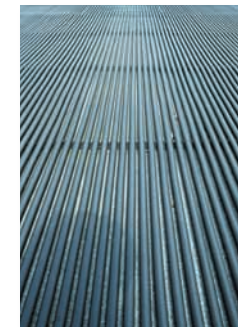

Manual

for installers, planners and operators/owners

Intelligent Energy  Europe



TABLE OF CONTENTS

1. INTRODUCTION

- 1.1 Why solar energy?
- 1.2 Why solar energy for outdoor swimming pools?

2. THE PROJECT SOLPOOL

- 2.1 Objectives and target groups
- 2.2 The project partners
- 2.3 Planned activities

3. SOLAR THERMAL SYSTEMS FOR OUTDOOR SWIMMINGPOOLS

- 3.1 Components
 - 3.1.1 Absorbers
 - 3.1.2 Pumps
 - 3.1.3 Heat exchangers
 - 3.1.4 Other components

4. SYSTEMS

- 4.1 Systems with no additional heating
- 4.2 Systems with auxiliary heating

5. PLANNING AND DIMENSIONING

- 5.1 The Impact Advisor

6. INSTALLATION

- 6.1 Installation of absorbers
 - 6.1.1 Mechanical fixing of absorbers
 - 6.1.2 Adhesive bonding of absorbers
 - 6.1.3 Further aspects to consider for the installation of absorbers
- 6.2 Pipeline installation
 - 6.2.1 Collection and distribution pipes
 - 6.2.2 Solar circuit
- 6.3 Operation and maintenance

7. COSTS AND YIELDS

8. A GOOD PRACTICE EXAMPLE

Solar heating in a public outdoor swimming pool

SOLPOOL

INTRODUCTION

1.1 Why solar energy?

The Sun represents the single greatest source of renewable energy known to mankind. Directly or indirectly, all the energy that we use comes from the Sun. The Sun radiation amounts to 15.000 times more than the energy we use at present. If it were not for the sun our existence on the planet would not be possible. The energy stored in fossil fuels originally came from the Sun. Ancient plants used sunlight as fuel to grow. Animals consumed these plants. The plants and animals stored the energy of sunlight in the organic material that composed them. When the ancient plants and animals died and decayed, this organic material was buried and gradually turned into the fossil fuels that we use today.

The sun gives us energy in two forms: light and heat. People have been

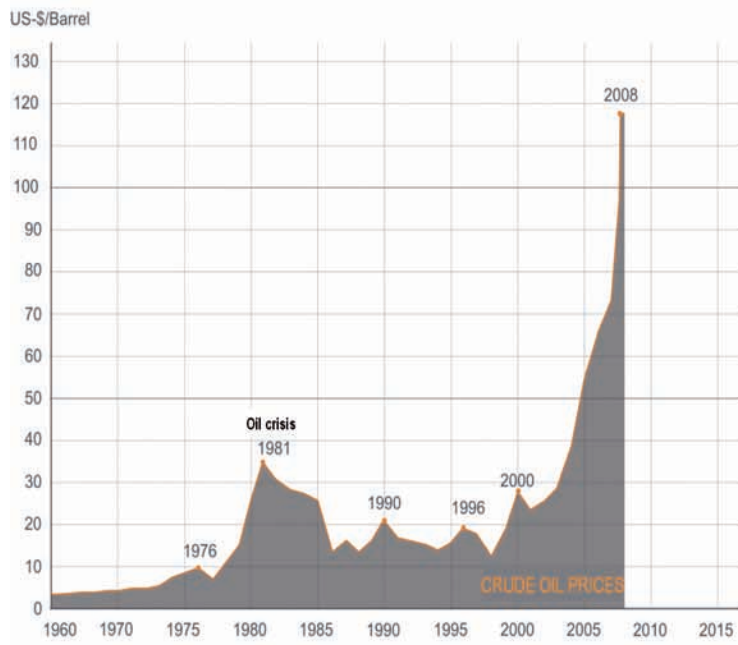

Figure 1: Development of oil prices from 1960 until 2008 (source: www.tecson.de)

using the sun's energy to make their homes brighter and warmer for centuries. The technical developments have increased the efficiency of the systems that capture the solar energy. By using solar energy we make our homes more comfortable and support at the same time, policies aiming to prevent climate change. As a result of it the dependency on fossil fuels is decreased, the air quality is improved and the greenhouse gas emissions are lowered. Moreover, the dependence upon oil imports with fluctuating prices is a major motivation in the support of alternative energy sources to dwindling fossil fuel deposits. In addition, production and maintenance of solar systems stimulates the job creation in the related sectors.

1.2 Why solar energy for outdoor swimming pools?

Solar thermal heating for outdoor swimming pools has some inherent advantages:

- Temperature level
The low temperature differences ranging from 18°C to 25°C make the use of inexpensive plastic absorbers possible.
- Solar radiation and seasonal operation
The time of highest solar radiation matches the swimming pool operating time frame. Outdoor swimming pools are operated from beginning/middle of May until the middle of September at latitudes in central Europe. During this period from 65% to 75% of the annual solar radiation occurs.
- Simple system design
The pool water flows directly through the absorber. Therefore, storage tanks necessary for other solar thermal systems are not required since the pool itself takes over their function.

Solar thermal heating for outdoor swimming pools has already been in place for decades and at present it is a well-established technology. However, that does not mean that this particular application of the solar thermal energy has reached its full potential.

2. THE PROJECT SOLPOOL

2.1 Objectives and target groups

The overall objective of the project is to increase the number of outdoor swimming pools equipped with solar thermal systems by 10% in every partner region/country.

The main target groups of the campaigns to be performed during the project are the owners and operators of swimming pools, as well as the installers of the solar thermal systems.

2.2 The project partners

The SOLPOOL consortium comprises a total of eight partners from seven different European countries including DGS (Deutsche Gesellschaft für Sonnenenergie) as coordinator together with TTZ Bremerhaven on the German side, ALE from France, ApE from Slovenia, CZREA from Czech Republic, Lecce from Italy, SAVE-REMA from Hungary and CRES from Greece.

2.3 Planned activities

The implementation of the SOLPOOL project will be performed following similar patterns in all the project regions/countries. A project website will be created in order to exchange and disseminate information and experiences among the project partners and target audiences.

The following main activities are foreseen:

- Analysis of the status quo (list of swimming pools, installers, manufactures, grant schemes, etc.)
- Implementation of campaigns for owners and operators as well as for installers
- Establishment of regional/national information centres
- Development of the Impact Advisor
- Workshops for owners/operators and installers
- Distribution of information panels to be placed at swimming pools

All the activities will be published in the project website www.solpool.info

3. SOLAR THERMAL SYSTEMS FOR OUTDOOR SWIMMING POOLS

3.1 Components

3.1.1 Installation of absorbers

Heating pool water is normally accomplished with unglazed and uninsulated solar collectors, which can provide moderate pool temperatures. This type of system is suitable for pools since the system operates with low temperature differences between the absorber and the surroundings and with relatively uniform return temperatures. Swimming pool absorbers are usually made of plastic (mostly EPDM, but also polypropylene and polyethylene), as the relatively low temperatures involved do not require greater heat capacity.

Because of the risk of corrosion of thermal collectors with copper absorbers, these can only be operated in solar systems for swimming pool heating if a separate solar loop with a heat exchanger is installed (i.e. indirect).

Apart from a few special designs, plastic absorbers can be subdivided into two groups:

- Tube absorbers
- Flat absorbers

Tube absorbers have a very simple design. A certain number of smooth or ribbed tubes are arranged in parallel and according to the design they are connected together with intermediate webs or by retainers at a given spacing. Absorber lengths of up to 100 m can be achieved and obstructions like chimneys or roof lights can easily be circumvented.

In the case of flat absorbers, sometimes also called plate or cushion absorbers, the channels are linked together structurally. This produces plates of different dimensions with a smooth surface. This has the advantage that there are no grooves in which dirt or leaves can accumulate and solidify. The self-cleaning effect during rain is also better. The influence of the design form on the conversion factor with different inclination angles can be measured but it is minimal. Variations of the angle of incidence lead to small differences in the conversion factor only for flat collectors. In the case of ribbed tube absorbers they lead to larger variations than with normal tube absorbers.

All absorbers are very easy to handle. The low weight (approx. 2 Kg/m²) and the flexibility of the material make it possible to install the system by only one person. The absorbers are not sensitive to mechanical stress and therefore it is possible to step and walk over them.

The following figures show a summary of the absorbers available on the market (Fig. 2) and different methods of connecting the absorber to the collection and distribution pipes (Fig. 3).

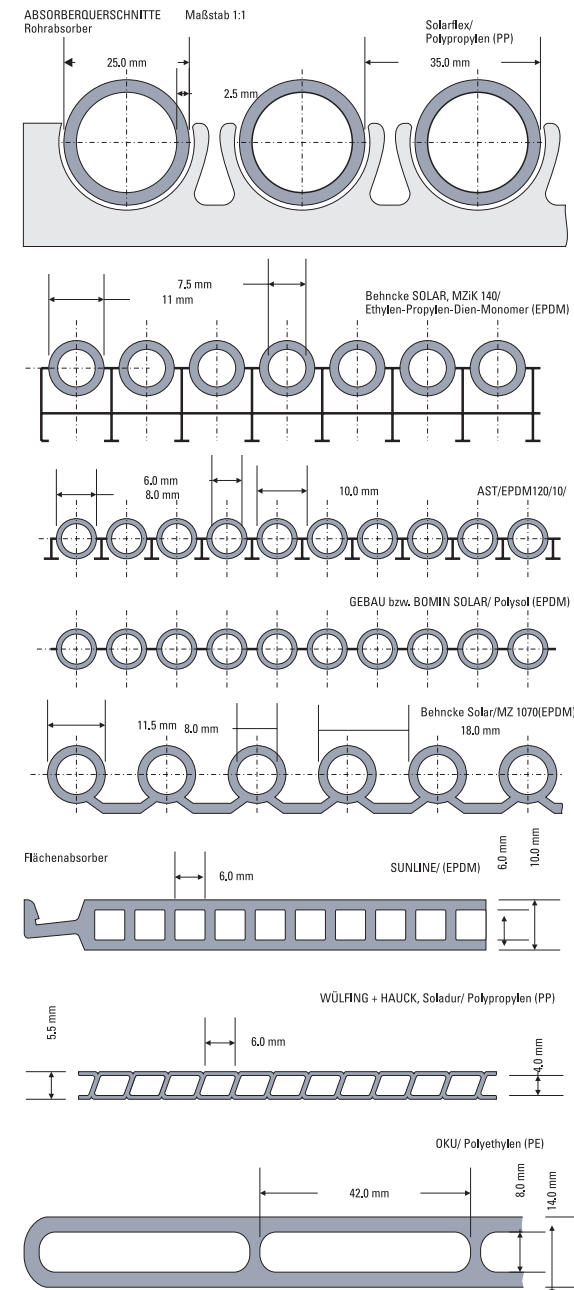

Figure 2: Different designs of absorbers in cross-section

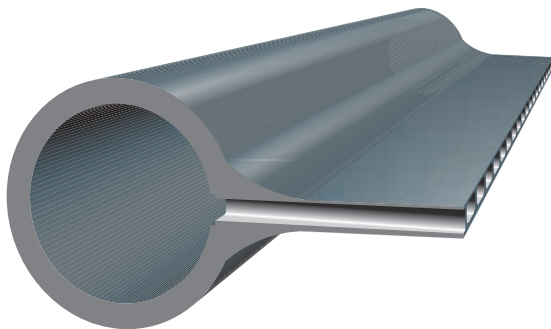
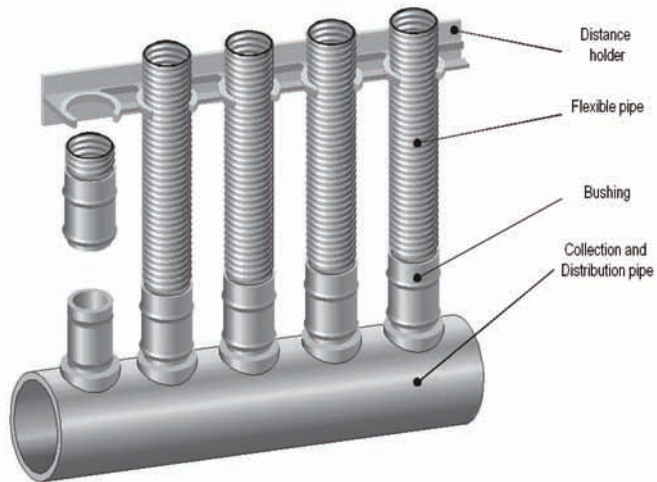
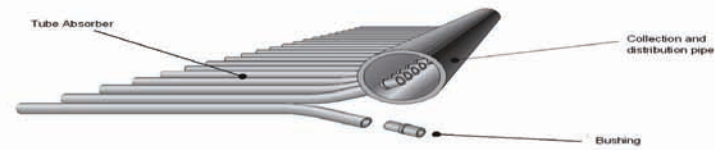

Figure 3: Different methods of connecting absorbers to the collection/distribution pipes

3.1.2 Pumps

The material properties of the pumps must fulfil the requirements for corrosion protection. Since it is normally not possible to use pumps without metal, corrosion-resistant materials should be used. The impeller, for instance, is usually made out of cast bronze and the shaft out of chrome nickel steel. The housing is usually made out of grey cast iron however plastic materials may also be employed. Some manufacturers also offer swimming pool pumps made completely out of plastic, such as glass fibre reinforced PP or POM (Polyoxymethaline). Some pumps available in the market have a pump shaft that does not come into contact with the swimming pool water. If the capacity of the existing filter pump is not sufficient to pump the swimming pool water through the additional absorber system, one or more supplementary pumps must be used.

Due to the great volumetric flow in comparison with solar domestic water systems and the resulting pipe diameters, the pumps are correspondingly dimensioned and have power settings of several kW, and even more in the case of very large systems.

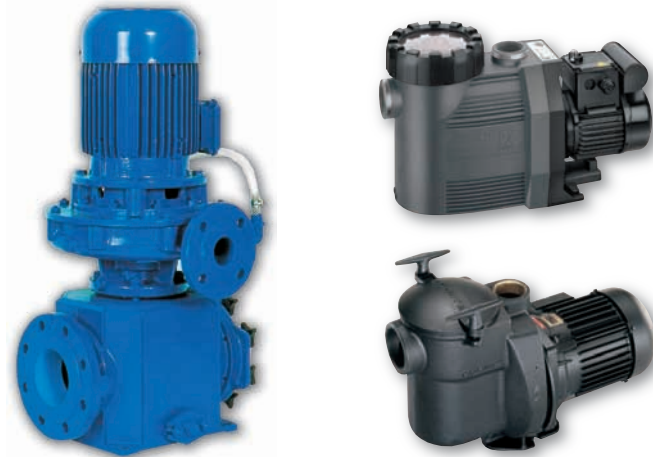

Figure 4: Circulating pump for solar circuits. Cast iron housing, chrome nickel steel shaft, cast iron or gunmetal impeller (source : Herborner Pumpentechnik)

3.1.3 Heat exchangers

Standard solar systems for outdoor pool heating have a simple system construction, in which no heat exchanger is necessary. However, if another type of heating is required, heat exchangers are necessary. In order to avoid corrosion problems caused by high concentrations of chloride ions in high-grade steel structures, the heating of chlorinated pool water should take place in high-grade plate heat exchangers. In any case the information provided by the manufacturer must be carefully considered. Manufacturers usually recommend a maximum concentration of 300mg/l of chloride ions. In the case that in the practice the maximum levels are exceeded, there are alternative shell and tube heat exchangers which are specially designed for swimming pools. They are made out of a copper-nickel alloy (CuNi10) and very good results have been obtained from years of operating experience. Any kind of heat source can be connected to them, either a heat pump or a gas condensing boiler and a temperature sensor can be placed for control purposes. As a general rule, shell and tube heat exchangers are usually employed in swimming pools.



Figure 5: Heat exchangers for swimming pool heating in high-grade steel (source: Büniger & Freese)

3.1.4 Other components

According to the system connection, pumps and/or partly motor-controlled valves are necessary for the operation of the system. Plastics are also used here for the valves. Such commercially available fittings for swimming pool systems can be obtained both in PVC, PE, or similar materials. In addition non-return valves, shut-off valves or slide valves and ventilators are required. These fittings are also standard accessories for swimming pool technology.



Figure 6: Three-way manual valve in PVC

4. SYSTEMS

4.1 Systems with no additional heating

Solar circuits in public open-air baths are normally operated with a separate solar circuit or absorber circuit pump. The hydraulic construction is much more complex than for private swimming pools because of the hygiene requirements. A system in a large outdoor pool works according to the following principle:

The swimming pool water is led from the pool into a central water storage tank. This tank acts as a “water level display” for the whole swimming pool water circuit. Evaporated water is replaced here by fresh water. The water is pumped through the filter from the water tank. One or several parallel-connected filter pumps are responsible for this. Subsequently, the water is returned to the pool via the water treatment system. The absorber field is connected to the circuit in a bypass system at the beginning of the water treatment system. The absorber loop pump diverts part of the volumetric flow and pumps it through the absorber field. The size of the partial volumetric flow depends on the size of the absorber field. The solar heated water is led to the main flow again after the diversion and finally gets back into the pool.

An automated valve should be installed in the absorber circuit feed line and a non-return valve after the solar pump. These two fittings prevent the absorber field from running empty when the system is not in operation.

Before the water reaches the pool, the hygiene parameters are set. Chlorine and other chemicals are introduced in order to regulate the pH value as necessary. The chlorine injection point should always be integrated behind the absorber field diverter since the chlorine concentration in the absorber circuit must not exceed 0.6 mg/l. Sudden high concentrations of chlorine (under certain circumstances up to 10 mg/l) may damage the absorber.

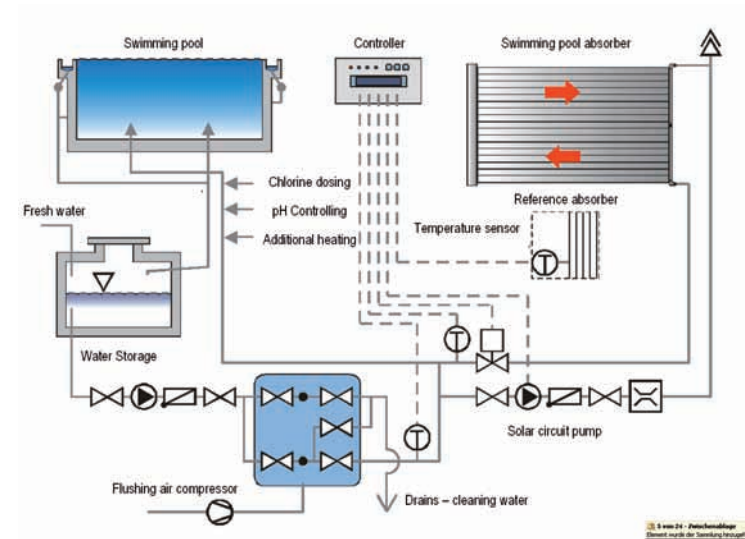

Figure 7: Circuit diagram of a large absorber system with additional solar pumps

4.2 Systems with auxiliary heating

Conventionally operated auxiliary heating is necessary if the pool water has to be maintained at a constant temperature. Some outdoor swimming pools offer their visitors warm swimming pool water independently of the sunshine, which requires auxiliary heating when the solar radiation is insufficient.

Auxiliary heating is operated by means of a conventional system (preferably gas heating systems) and an additional heat exchanger. In a dual-heated system, the auxiliary heating should always follow the solar heating. If the water does not reach the required temperature level after recirculation to the filter circuit, the auxiliary heating covers the remaining heat requirements.

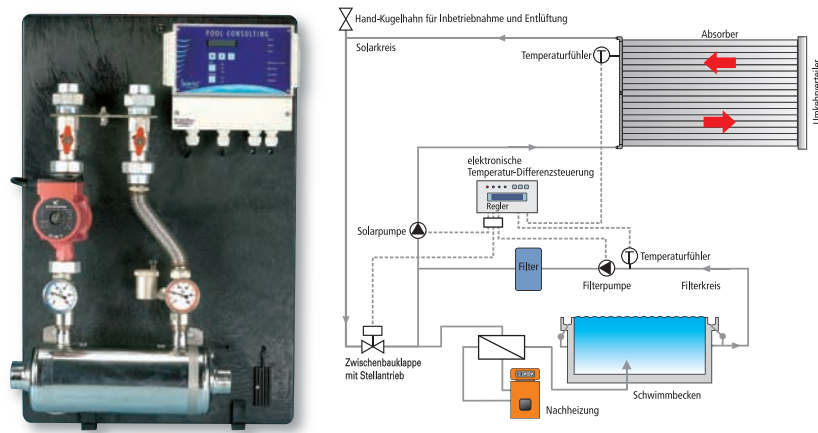

Figure 8: Integration of auxiliary heating

5. PLANNING AND DIMENSIONING

Like in the case of solar thermal systems for domestic water heating, the prevailing solar radiation and heat consumption conditions are of great significance at the planning stage of solar swimming pool heating systems. The heat consumption of a swimming pool depends on the following parameters:

- Pool surface
- Depth of water
- Colour of the pool
- Desired water temperature
- Availability of a pool cover
- Ambient meteorological conditions (Temperature, wind speed, etc)

Solar heating systems can provide up to 100% of the pool heating needs in open-air pools with a proper system dimensioning. Since the solar radiation between May and September fluctuates, there are slight water temperature variations at the beginning and at the end of the swimming season as well as by bad weather conditions. However, it does not affect the enjoyment of the visitors. In lengthy periods of bad weather, the few

regular swimmers must expect and accept a lower pool water temperature compared to a conventionally heated pool.

The Impact Advisor

The Impact Advisor is a decision tool for the implementation of solar thermal heating in outdoor swimming pools. It offers owners/operators as well as installers and planners the main information for the preparation of a project.

The input parameters are:

- Location
- Energy consumption per operating period
- Energy costs
- Desired mean water temperature

The output parameters are:

- Necessary absorber surface area
- Estimated investment costs
- Estimated energy savings
- Payback time

The developed tool is based on the calculations performed with the T*SOL software, version expert 2.2. The following assumptions have been made:

- The beginning and end of the operating period is mainly determined by the air temperature. As experience shows, the threshold value is 20°C. Therefore, the simulation period covers those months where that minimum ambient temperature is reached.
- There is a linear correlation between the ratio of absorber, pool surface area and mean pool temperature

- The operating pool water heating system does not have an auxiliary conventional heating system.
- No pool cover has been considered

These are the calculated outputs from the Impact Advisor for a case scenario of a pool without cover, 100 m² surface area, average pool depth of 2m, number of pool users 50 Persons/day, and fresh input water 1.400 Litres/day.

SOLPOOL – IMPACT ADVISOR

Owner/operator	
Name	Walter
First name	Fritz
Street	Betzenberg
Post code, city	67655 Kaiserslautern
Basic data	
Heating System	Electric Energy
Energy consumption	200.000,00 kWh/a
Energy costs	20.000,00 EUR/a
Energy price	0,10 EUR/kWh
Global radiation of reference city	D-Hamburg – 950 kWh/m ² a
Pool length	50,00 m
Pool width	20,00 m
Pool surface area	1.000,00 m ²
Target pool temperature	22,00 °C
Results	
Type of collector	Absorber
Ratio of absorber area to pool area	1,21
Absorber area	1.205,88 m ²
Specific solar yield	300,00 kWh/m ² a
Energy savings	361.764,71 kWh/a
Cost savings	36.176,47 EUR/a
Specific system costs	100,00 EUR/m ²
Investment costs	120.588,24 EUR
Payback period	3,33 a
Emissions value	647,00 g/kWh
CO ₂ -Savings	234.061,76 kg/a

Figure 9: Interface Impact Advisor

6. INSTALLATION

6.1 Installation of absorbers

Absorbers can be installed on flat roofs as well as on roofs with inclination. It is also possible to install them at ground level. Since the primary use occurs during the summer months where the elevation angles of the sun are greater than 50° , it is not necessary to install the absorbers on elevated tracks. If an inclined surface is to be used then an alignment to the south in the range of -45° to $+45^\circ$ is advantageous.

The installation of the absorber is strongly dependent on the type (tube or flat absorber) and the background conditions. The structural strength of the roof plays only a minor role here. The absorber itself when filled has an approximate weight of $8\text{--}12\text{ kg/m}^2$ depending on the design. Concrete slabs are used to secure the absorber field from wind. In this case the surface load can be considerably higher than the absorber field and therefore, the structural strength of the roof must be checked previously.

Whenever roof perforations are made, it is essential that they are closed again afterwards. If possible, fixings which do not require any roof perforation are preferred, e.g. flat roof installation on concrete slabs as already mentioned.

6.1.1 Mechanical fixing of absorbers

In many applications the absorber is installed on a flat roof or a slightly inclined roof. Mechanical fixing for the absorber in the form of webbing or steel rails is suitable here. The key aspect is to secure the absorber from wind forces. In the case of public outdoor pools, installation on flat roofs with wind security provided by concrete slabs has been found to be the simplest and cheapest solution. The concrete slabs must have protection mats underneath them in order to protect the roof. As shown in Fig. 10 the installation system can be mounted on concrete slabs. The absorbers are then fixed between two concrete slabs using webbing or aluminium rails. Webbing has been found to be the cheapest and most versatile system for this. The absorbers are

clamped with one upper and one lower chord perpendicular to the direction of flow. The distance from one belt to the next should not be greater than 1.5 m. At regular intervals (also about 1.5 m) the upper and lower belts should be fixed with UV resistant cable binders.

The installation of absorbers with tension belts is also suitable for pitched roofs. In this case, another type of point fixing must be chosen, which will vary according to the type of roof. This is also applicable for steel rails that are more frequently used for pitched roof installation. In the case of tiled roofs common roof hooks can be used for point fixing.

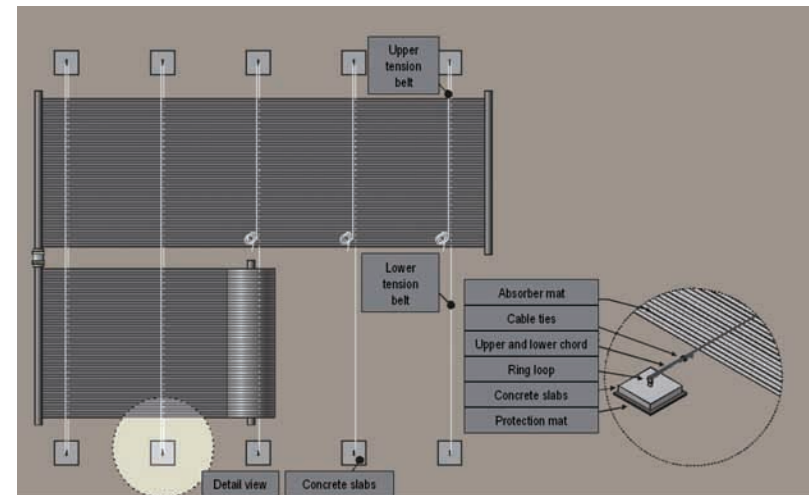

Figure 10: Fixing of absorbers with tension belts and concrete slabs on a flat surface

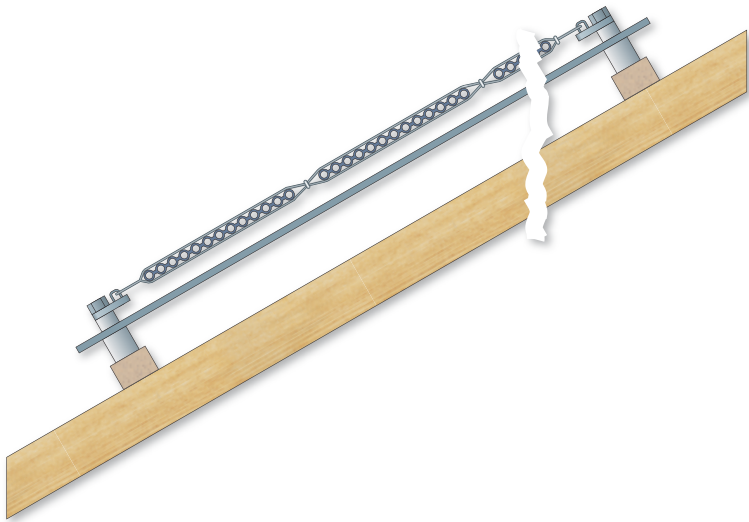

Figure 11: Clamping of absorbers with belts on an inclined roof

6.1.2 Adhesive bonding of absorbers

The surface area of most of the common types of roof coverings (tiles, sheets of metal, bitumen, etc) is smooth enough to be able to bond the absorber to the background with a special adhesive, which is usually available from the manufacturers. According to the manufacturer's system and the roof pitch, the adhesive layers should be applied at intervals of 30 to 100 cm. Some types of absorbers have cross pieces on the back, which do not only provide an insulating air cushion but also an additional support surface for bonding purposes. If inclinations are greater than 30° it is necessary to make sure that absorbers do not slip until the adhesive has hardened. For this purpose a double-sided adhesive absorber mounting tape can be fitted close to the adhesive material. Before bonding of absorbers it is important to check first that the surface aimed for the installation is dry, free of grease and dirt.

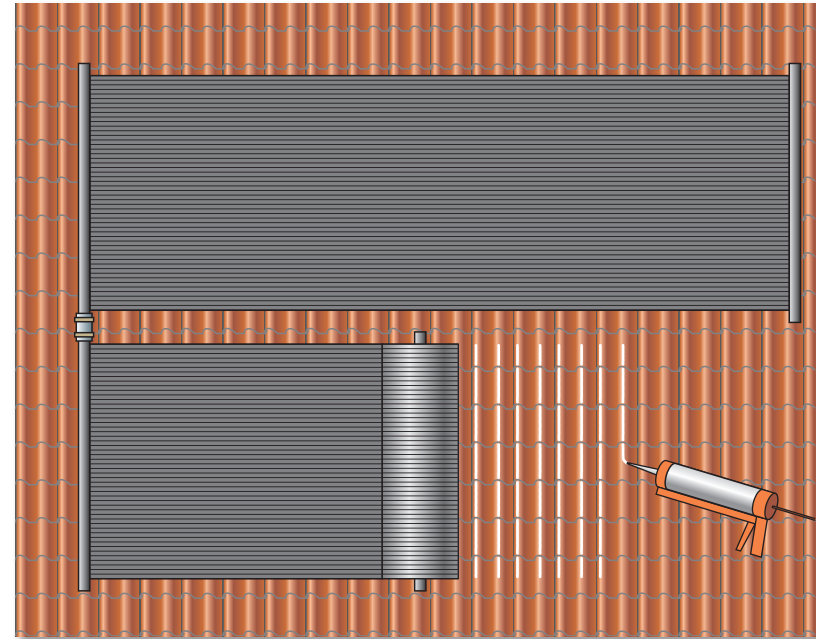

Figure 12: Bonding of absorbers on a pitched tiled roof

6.1.3 Further aspects to consider for the installation of absorbers

As already indicated in the design section of the present manual, it may be the case that insufficient roof surface is available for the required absorber area, particularly in the case of public swimming pools, where several hundreds of square meters are necessary. Under certain circumstances it may be possible to install the system at ground level, securing the installation from wind in the same way as for roof installation. It is also essential to protect the absorber from plant or weed growth. For this purpose the flattest possible surface should be prepared allowing rainwater to seep through easily and preventing long term plant growth. In addition it is important to add a layer of round gravel so that the absorber is not damaged by sharp stones when stepping on it.

In order to achieve greater protection the absorber area can be fenced. Low hedging at a suitable distance protects the absorber field from wind and hence reduces heat losses by convection.

The company SOLKAV has developed an absorber that can be walked and

played on. It can be used anywhere where there is not enough roof area available or where previously it was impossible to install a solar system for optical or technical reasons, SPORT SOLAR is a combination of solar absorber technology for heating swimming pools and a surface that can be walked on and thus can be used for instance as a swimming pool border



Figure 13: Sport Solar absorber (source: SOLKAV)

6.2 PIPELINE INSTALLATION

The relevant technical regulations such as EN 805 should be used for installation works. In addition, the pipe lengths between the absorber field and the swimming pool should always be chosen so that they are as short as possible. Due to the low operating temperatures thermal insulation is not normally used for the pipes. Special attention should be paid to the linear expansion of the plastic pipes due to the different operating temperatures.

6.2.1 Collection and distribution pipes

In general, the type of fixing strongly depends on the selected absorber system and the type of roof available. The collection and distribution pipes are either fixed to the roof with screw clamps or with anchors similar to those used for the on-roof assembly of flat collectors.

Since the absorber collection and distribution pipes are usually made of PE-HD or PVC, the temperature-related expansion must be taken into account. Individual pipes can for instance be linked by rubber

sleeves. If the pipes to be connected do not directly butt against each other, the temperature-related expansion can be compensated by the rubber sleeve.

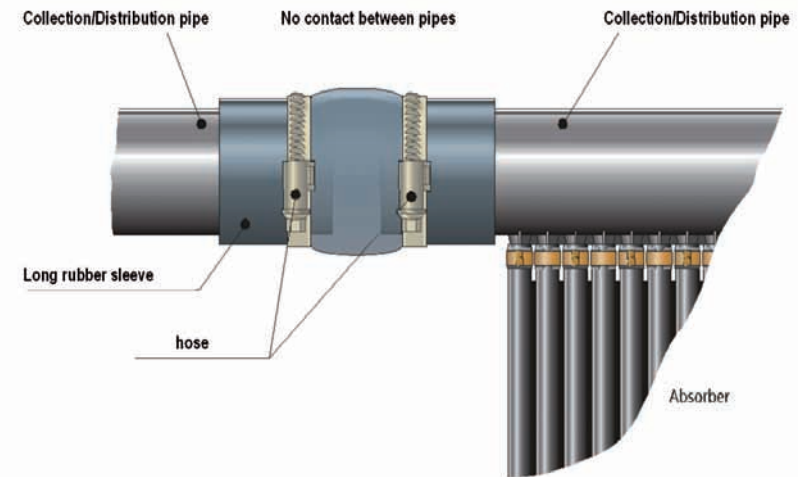

Figure 14: Rubber sleeve connectors for collector pipes to compensate for temperature-related expansion

6.2.2 Solar circuit

The piping for the solar circuit consists of plastic pipes. PVC pipes are often used but if possible PE or PP pipes should be used for environmental reasons. The pipes are fitted to buildings with screw clamps and between the building and the swimming pool the pipes should be placed underground whenever possible. PVC pipes are connected together with a suitable adhesive. The common grey PVC pipes must not be subject to UV radiation and therefore should be placed under the roof, underground, or they should be given a protective coating. Black PVC pipes and the corresponding fittings are however permanently UV-resistant.

PE and PP pipes can be connected together by the so-called heating element stub welding. Since this method is significantly more expensive than gluing PVC pipes, it is mainly used in municipal swimming pools and requires the corresponding expertise for installation. The ends of the pipes must have a smooth surface, cut perpendicular to the axis of the pipe, so that permanent leak-proof connection can be achieved. The heating element in the form of a thin disc is guided between the pipes to be joined, where it heats the ends of the pipe. The pipes are in a holder to ensure that the pipe axes match with each other. The heating element is then removed and the ends of the pipes are pushed together under pressure.

Long pipelines should be attached at one fixed point, in a floating arrangement to allow linear expansion. The temperature range in which the pipes operate extends from -20°C in winter to $+70^{\circ}\text{C}$ when the absorber pump is switched off (stagnation). A heat expansion coefficient of $0.2\text{ mm}/(\text{m}\cdot\text{K})$ (for comparison copper is $0.016\text{ mm}/(\text{m}\cdot\text{K})$) and a 30m pipeline means a length change of 54 mm. The pipeline should be fitted on freely floating loose seating. Furthermore, flexible sections and expansion bends should be installed at regular intervals from the fixed points (10-15 m).



Figure 15: Example of sliding installation of pipes with anchor clamps

6.3 Operation and maintenance

On a general basis, solar systems in outdoor swimming pools are fully automated. The control unit takes over the operation and switches the absorber pumps on and off. After a new installation intervention may be necessary in the control strategy, but this must be performed by an expert. At the beginning of the swimming season the absorber surface should be checked for contamination and brushed off or spray-washed as necessary. The use of high-pressure cleaning is not recommended because of the risk of damaging the absorber. In addition, it is important to bleed the system thoroughly just before the season starts, which in the case of large and multiple absorber fields, represents a significant cost due to the necessary manual work.

Especially in the case of public swimming pools, it is recommended to give the personnel a basic introduction to the operation of the solar system so that they can check the operating parameters at regular intervals and also they should be able to recognise error functions. A control system that provides yield figures makes this work easier. Those figures can then be used both for regular checks and to provide the swimmers with visual information at a suitable location.

Individual damage to absorbers can be fixed in a very simple way. A damaged tube can be completely or partially exchanged between the collector and distributor. The damaged piece is cut out and repaired with a new absorber tube, sleeves and the necessary clamps.

At the end of the season the absorber field should be emptied. Even if EPDM absorbers survive frost without damage, germs can build up in water that is standing for a long period of time. PP absorbers must be emptied since they are not frost resistant. Compressed air is normally used for the emptying process. The collection and distribution pipes as well as the solar circuit are emptied with a drain valve.

In the field of solar pool heating there is no risk regarding Legionnaire's bacteria formation since it is prevented by the chlorine used for disinfection purposes.

7.COSTS AND YIELDS

The average solar energy yield of the system per swimming season (mid-May to mid-September) is approx. 250-350 kWh/m², i.e. the system operates with a solar radiation of ~650-700 kWh/m² per season, with an average system utilisation of ~40-50%.

In terms of economics a solar single-source heating system for outdoor swimming pools is the most advantageous. In Table 1 two heating systems are compared: one conventional gas heating system and one solar heating system. The assumed boundary conditions are 1620 m² pool surface, 900 m² absorber surface, period under consideration 15 years, annual interest rate 6% and standard assumptions for maintenance and operating costs.

The comparison with conventional energy costs shows that solar outdoor swimming pool heating is more economic than conventional heating, even if a grant scheme does not exist.

In the case of a dual-fuel system, the solar system can also provide cost benefits since conventional fuel is saved anyway. Economic operation is however only possible within a limited range of certain parameters. The most influential parameters here are conventional fuel costs and the desired temperature of the swimming pool water.

Subcontracting models can be of interest for local authorities in the case of a lack of financial support. In this case the local authorities would only have to pay for the solar heated swimming pool water.

Table 1: Comparison of gross annual costs for two different single-source heating systems

	Conventional heating (gas)	Solar heating
Investment	36.000 EUR	81.800 EUR
Capital costs	3.708 EUR/a	8.425 EUR/a
Energy consumption	325.000 kWh/a	276.000 kWh/a
Auxiliary energy	1.625 kWh/a	3.100 kWh/a
Fuel consumption	342.000 kWh/a	–
Gas and electricity costs	14.196 EUR/a	465 EUR/a
Maintenance	715 EUR/a	818 EUR/a
Total annual costs	18.619 EUR/a	9.708 EUR/a
Heat price	0,054 EUR/kWh	0,035 EUR/kWh

8. A GOOD PRACTICE EXAMPLE

Solar heating in a public outdoor swimming pool

The summer swimming pool in Pankow is one of the ~13 outdoor pools from the Berlin swimming pool authority. The open-air complex underwent extensive renovation works at the end of the nineties.

In the year 2000 a solar thermal system with an absorber area of 520 m² was installed. The dimensioning of the system was not ideal for a swimming pool area of 1500 m², and therefore in the year 2001 the solar system was extended to a total of 1150 m², i.e. an additional absorber surface area of 630 m².

The installed solar pumps from the company Herborner have a total capacity of 115m³/h, i.e. 100l/m²h. The hydraulic interconnections of the system prove here to be advantageous since the PP Solar-flex[®] absorbers from the company Solaranlagen Lange GmbH (Telgte) have even in long paths a relative small pressure loss.



Figure 16: Solar thermal system for swimming pool heating in Pankow, Berlin (source: DGS)

System data:

Collector surface area	1.150 m ²
Pool surface area	1.500 m ²
Starting up	2000/2001
Operator	Berlin swimming pool authority Contact person Mr. Thoma
Installation of the system	Solaranlagen Lange GmbH, Telgte
Planning	Solaranlagen Lange GmbH, Telgte
Yield	~350 MWh/a, 285 kWh/m ² a
Degree of utilisation	~45 %

Sustainable Energy Europe



The Project SOLPOOL is an official partner of the campaign Sustainable Energy Europe from the European Commission.

Intelligent Energy Europe

Intelligent Energy  Europe

The SOLPOOL project receives funding from the European Commission within the ALTENER Programme. The sole responsibility for the content of this document lies with the authors. It does not necessarily reflect the opinion of the European Communities. The European Commission is not responsible for any use that may be made of the information contained therein.